

RG-200

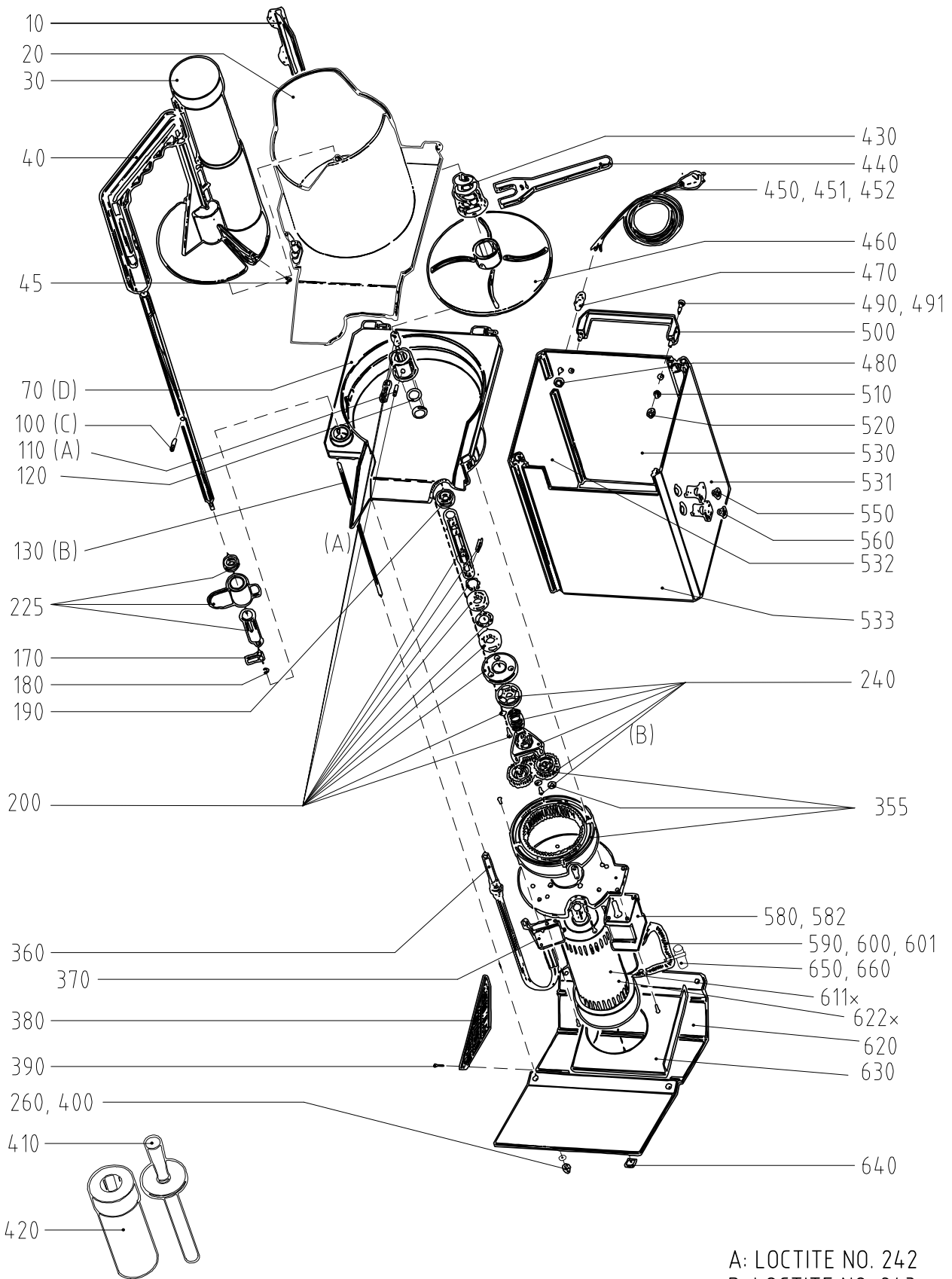

A: LOCTITE NO. 242
 B: LOCTITE NO. 243
 C: LOCTITE NO. 270

D: SILICONE RTV 108 ALL THE WAY AROUND HOUSING

RG-200

No. on drawing	Item No.	Description	Pcs
10	1171	Partition wall compl.	1
20	1188	Feed cylinder compl.	1
30	83038	Pestle	1
40	1180	Feeder plate compl. incl shaft	1
45	40839	Slide knob	1
70	1407	Knife chamber RG-200	1
100	1290	Guide pin	1
110	3152	Carrier pin for ejector plate	2
120	10262	Seal ring V-18S	1
130	1039	Screw L=316	4
170	1073	Activator CE/ STD	1
180	10275	Locking washer RS 4	1
190	10259	Rubber seal washer 18X30X7	1
200	1402	Knife shaft kompl RG-200/ RG-250	1
225	1091	Locking handle compl.	1
240	1403	Brake kompl. RG-100/200/250.	1
260	14085	Lock washer FBB 5,1 A2	8
355	1098	Planetwheels and gearing kit	1
360	15354	Magnetic switch HM-S-16	1
370	1584	Micro switch unit	1
380	1096	Louver kit	1
390	14248	Screw KFX-H ST3,5X9,5 A2 70	6
400	1267	Nut, domed head M5	4
410	81066	Pestle	1
420	1155	Tube	1
430	1172	Decoring device	1
440	1184	Wrench for decoring device	1
450	15147	Supply cord CB 1 phase RG-100/200/250/350/vcb-61/vcm-41	1
451	15377	Supply cord BS/2.5MS UK	1
452	15278	Suply cord 439/2.4MG SJT	1
460	1159	Ejector plate	1
470	15688	Cable retainer, PG9 (8)	1
480	15692	Nut PG 9 plastic	1
490	14374	Screw MCS M8X20 A2 70	2
491	10306	Plug	2
500	10043	Handle M443/140	1
510	14088	Lock washer FBB 8.2 A2	2
520	14008	Nut M6M M8 A2 70	2
530	1365	Machine casing back part	1
531	1362	Machine casing right part	1
532	1364	Machine casing left part	1
533	1363	Machine casing front part	1
550	15657	Push button o compl.	1
560	15440	Push button 1 complete	1
580	15813	Contactactor 11BG0910A110	1
582	15810	Contactactor 11BG0610A230	3
590	15384	Fuse T100MA	1
600	1104	Wiring loom UL AWG compl.	1
601	15385	Fuse holder	1
611	*	Motor	1
620	1095	Base plate compl.	1
622	*	Capasitor	1
630	1170	Fan plate	1
640	10273	Rubber foot SJ 5023 black	4
650	15111	RC-circuit 110v	1
660	15110	RC-circuit 230v	1

* Contact HALLDE for more information when ordering (supply your serial number).

SPARE PARTS CUTTING TOOLS FOR RG-100, RG-200, RG-250 diwash, RG-250 AND RG-7

Cutting Tool	No. on drawing	Item No.	Description
Slicer	10	63303	Knife, Slicer 0.5-1 mm
	20	63324	Knife, Slicer 1.5-10 mm
Crimping Slicer	30	63301	Knife, Crimping Slicer
Julienne Cutter	40	63331	Kit spare part Julienne 2x2m
		63354	Kit spare part Julienne 2x6 mm
		63357	Kit spare part Julienne 3x3 mm
		63332	Kit spare part Julienne 4x4 mm
		63333	Kit spare part Julienne 6x6 mm
		63334	Kit spare part Julienne 8x8 mm
Grater/Shredder	50	87101	Plate for 1.5 mm, Grater
		87102	Plate for 2 mm, Grater
		87103	Plate for 3 mm, Grater
		87104	Plate for 4.5 mm, Grater
		87105	Plate for 6 mm, Grater
		87106	Plate for 8 mm, Grater
		87107	Plate for 10 mm, Grater
Fine Grater	60	87108	Plate, Fine Grater
	70	87109	Plate, Grater Extra Fine
	80	87110	Plate, Hard Cheese Grater

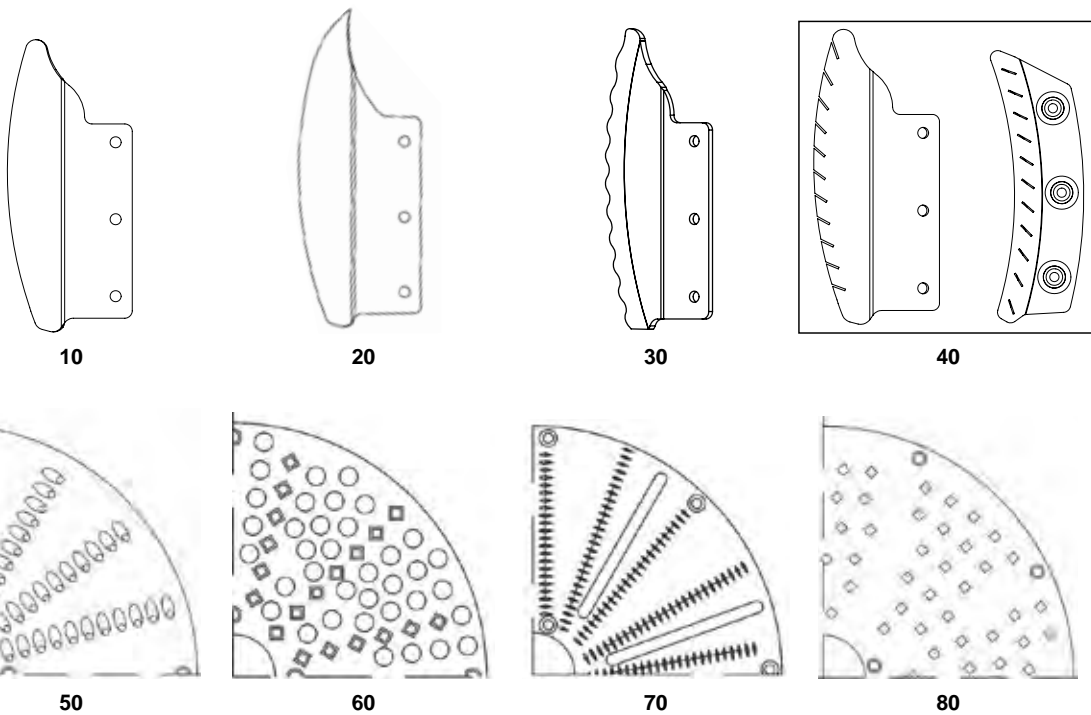

SPARE PARTS CUTTING TOOLS FOR RG-100, RG-200, RG-250 diwash, RG-250 AND RG-7

Cutting Tool	No. on drawing	Item No.	Description
Standard Slicer	90	87111	Knife, Standard Slicer
Fine Cut Slicer	100	87112	Knife, Fine Cut Slicer
Crimping Slicer	110	87113	Knife, Crimping Slicer
Soft Slicer	120	87114	Knife, Soft Slicer
Julienne Cutter	90	87111	Knife, Standard Slicer
	130	87116	Horizontal knife, 4.5x4.5 mm
		87117	Horizontal knife, 6x6 mm
		87118	Horizontal knife, 8x8 mm
		87119	Horizontal knife, 10x10 mm
	140	87120	Kit Knife block, 2x2 mm
		87121	Kit Knife block, 2x2 mm CC
		87122	Kit Knife block, 2.5x2.5 mm
	150	87123	Kit Knife block, 4.5x4.5 mm
		87124	Kit Knife block, 4.5x4.5 mm CC
		87125	Kit Knife block, 6x6 mm
	87126	Kit Knife block, 8x8 mm	
	87127	Kit Knife block, 10x10 mm	
Potato Chip Grid for RG-7, RG-250 diwash and RG-250	160	3797	Compl. kit knives Potato Chip Grid
Dicing Grid for RG-7, RG-200, RG-250 diwash and RG-250	170	82357	Compl. kit knives, 10 mm
		82358	Compl. kit knives, 12.5 mm
		82361	Compl. kit knives, 25 mm
Dicing Grid for RG-200, RG-250 diwash and RG-250	180	82346	Center ring di. 34 aluminium

