

VEGETABLE PREPARATION MACHINE / CHEESE SHREDDER RG-400i

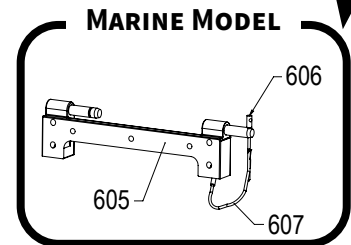
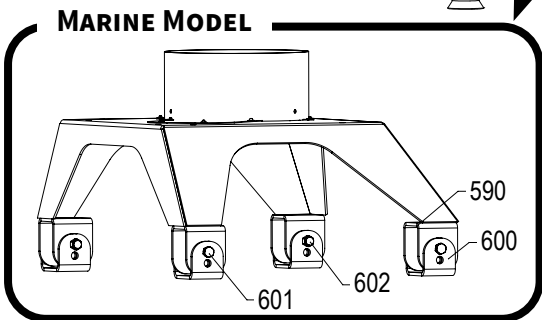
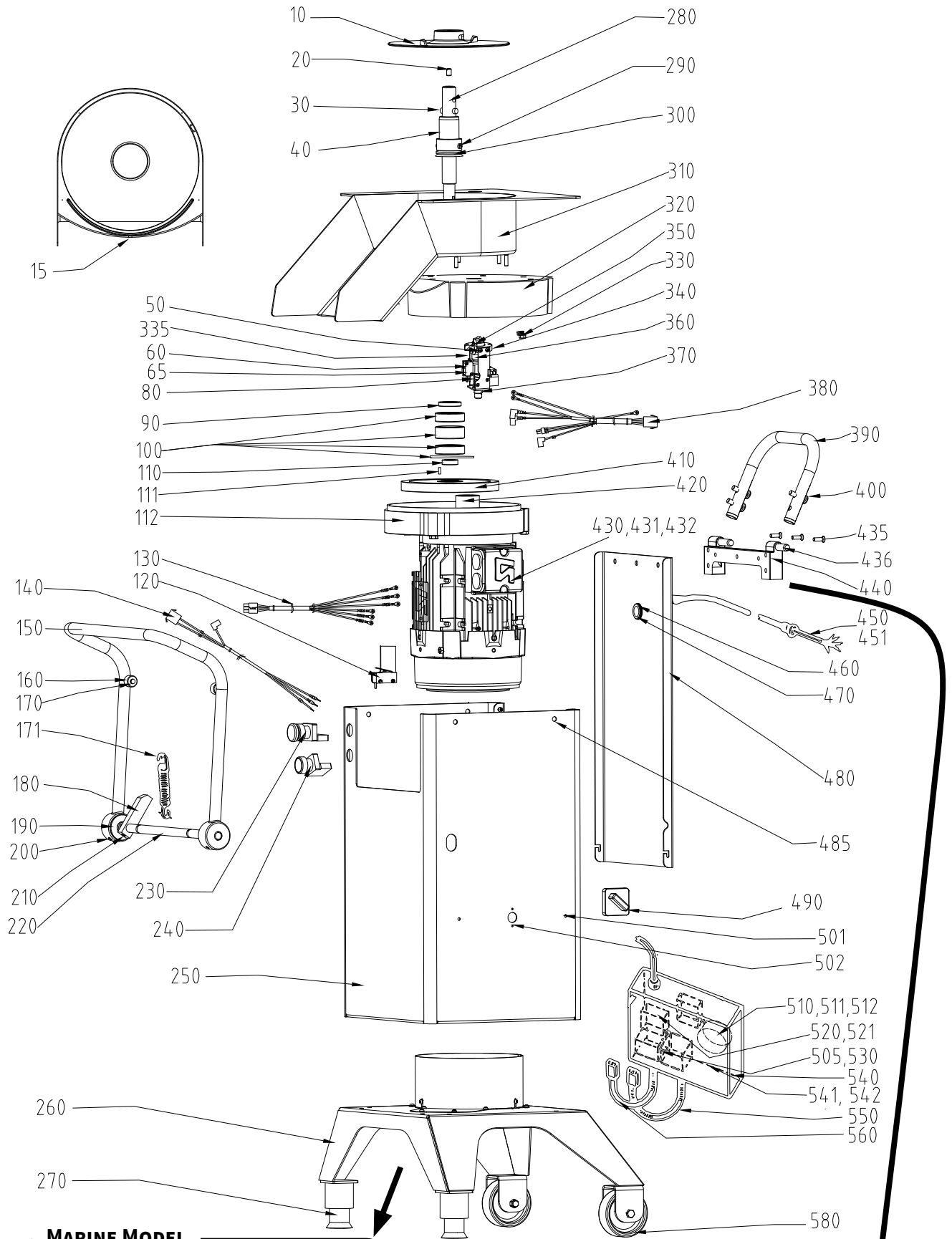

VEGETABLE PREPARATION MACHINE / CHEESE SHREDDER RG-400i

No. on drawing	Item No.	Description	Pcs
10	37042	Ejector plate	1
15	37297	Tray	1
20	14844	Locking screw PSS M8X 12 A2 70	1
30	40548	Carrier pin	1
40	37389	sleeve	1
50	14853	Screw MRT M4X6 A2	4
60	37215	Micro switch unit kompl.	1
65	37245	Micro switch XGT2C-86-Z1	1
80	10324	Spring, safety switch 22510	1
90	10318	Seal ring 25X40X7	1
100	37152	Ball bearings kompl.	1
110	3056	Spacer ring 20/28	1
111	10321	Key PKR 6X6X16	1
112	37158	Motor bearer complete	1
120	37343	Micro switch complete XGG2A	1
130	3194	Wiring loom motor	1
140	37367	Wiring loom, machine	1
150	37017	Lock handle	1
160	37217	Roller locking handle	2
170	10326	Lock ring SGA 8 SS	2
171	3111	Tension spring	2
180	3108	Stopper for lock handle	1
190	3089	Bushing for lock handle	2
200	14849	Screw TSS 8X25 A2 70	2
210	14845	Screw TSS 8X15 A2 70	1
220	37020	Shaft lock handle	1
230	15439	Push button o complete	1
240	15440	Push button 1 complete	1
250	37075	Machine housing front part	1
260	37052	Base	1
270	37154	Feet complete	1
280	37072	Knife shaft complete	1
290	37059	Carrier pin for ejector plate	2
300	10311	Seal ring V-35S	1
310	37001	Knife chamber	1
320	37006	Gearbox top	1
330	14006	Nut M6M M6 A2 70	6
335	10539	O-ring 21.1X1.6	1
340	37047	Casing for switch	1
350	10325	Seal ring 17.1X1.6	2
360	37172	Shaft safety switch	1
370	37250	Bushing	1
380	37366	Wiring loom, machine	1
390	3110	Handle knifechamber	1
400	14375	Screw MCS M8X25 A2 70	4
410	37156	Gear wheel 173.2 complete	1
420	37155	Gear wheel 53.6 complet	1
430	15435	Motor 400-415 3 50	1
431	15433	Motor 220 3 50 4-8 RG-400	1
432	15432	Motor 208-220 3 60 UL	1
435	14269	Screw MKFS M6X25 A2 70	3
436	37171	Seal ring	1
440	37018	Hinge	1
450	15144	Supply cord CB 3 phse	1
451	3193	Supply cord US	1
460	15381	Cable ret PR 22.5 dia 15	1
470	15443	Nut PR 22.5/PG16 metal	1

VEGETABLE PREPARATION MACHINE / CHEESE SHREDDER RG-400i

No. on drawing	Item No.	Description	Pcs
480	37023	Machine housing back part	1
485	14464	Screw LKCSF M6X16	4
490	15442	Pole changing switch incl knob	1
501	14428	Screw M4x20 A2 70	2
502	14853	Screw MRT M4X6 A2	2
505	15718	Varistor S20K510	1
510	15589	Transformer 208-240v 22-26v UL	1
511	15611	Transformer 400/380V-24 50VA	1
512	15689	Transf. 440-415V 24 100VA 80C	1
520	15814	Overl. rel. RF12400	1
521	15816	Overload RF120630	1
530	15825	Contacto 11BG0910A024	2
540	15587	Box CT-841	1
541	15152	Fuse	1
542	15672	Insulation sleeve 6.3-0.8 FLAG	1
550	3195	Wiring loom pole changening	1
560	3192	Wiring loom electrical box	1
580	37153	Wheel complete	1
590	37501	Base Marine	1
600	37503	Weld plate	4
601	14553	Screw M6S M8X70 A2 70	4
602	14028	Nut MHM M8	4
605	37509	Hinge Marine	1
606	37511	Hinge locking pin	1
607	37513	Wire	1

VEGETABLE PREPARATION MACHINE / CHEESE SHREDDER RG-400i: CHEESE FEEDER

No. on drawing	Item No.	Description	Pcs
10	37148	Stand complete	1
15	10335	Lock ring SGA 10	3
20	3297	Pivot L=51	3
30	37666	Link Cheese	1
40	3299	Pivot L=34	1
50	37630	Push handle Ergo Cheese	1
60	37661	Feeder plate including shaft	1
70	3074	Bushing for stand	2
80	10452	Plug SFL 14	1
90	3257	Guide knob	3
100	37244	Bushing	1
105	37618	Shaft stand Cheese	1
110	14149	Screw MFS M5X16	1
115	3212	Pin for stand L=28	1
120	3253	Bayonet sleeve	1
130	37162	Locking clutch complete	1
140	37243	Bushing	1
150	37151	Bushing holder complete	1
160	37611	Feed Cylinder, Cheese Shredder	1
165	37149	Stopper complete	1
170	37097	Slide knob	1
180	37022	Locking distance	2
185	14121	Screw MFS M4X6 A2 70	4
190	3162	Wrench	1
200	3129	Decoring device 3ph	1

