

VEGETABLE PREPARATION MACHINE RG-400

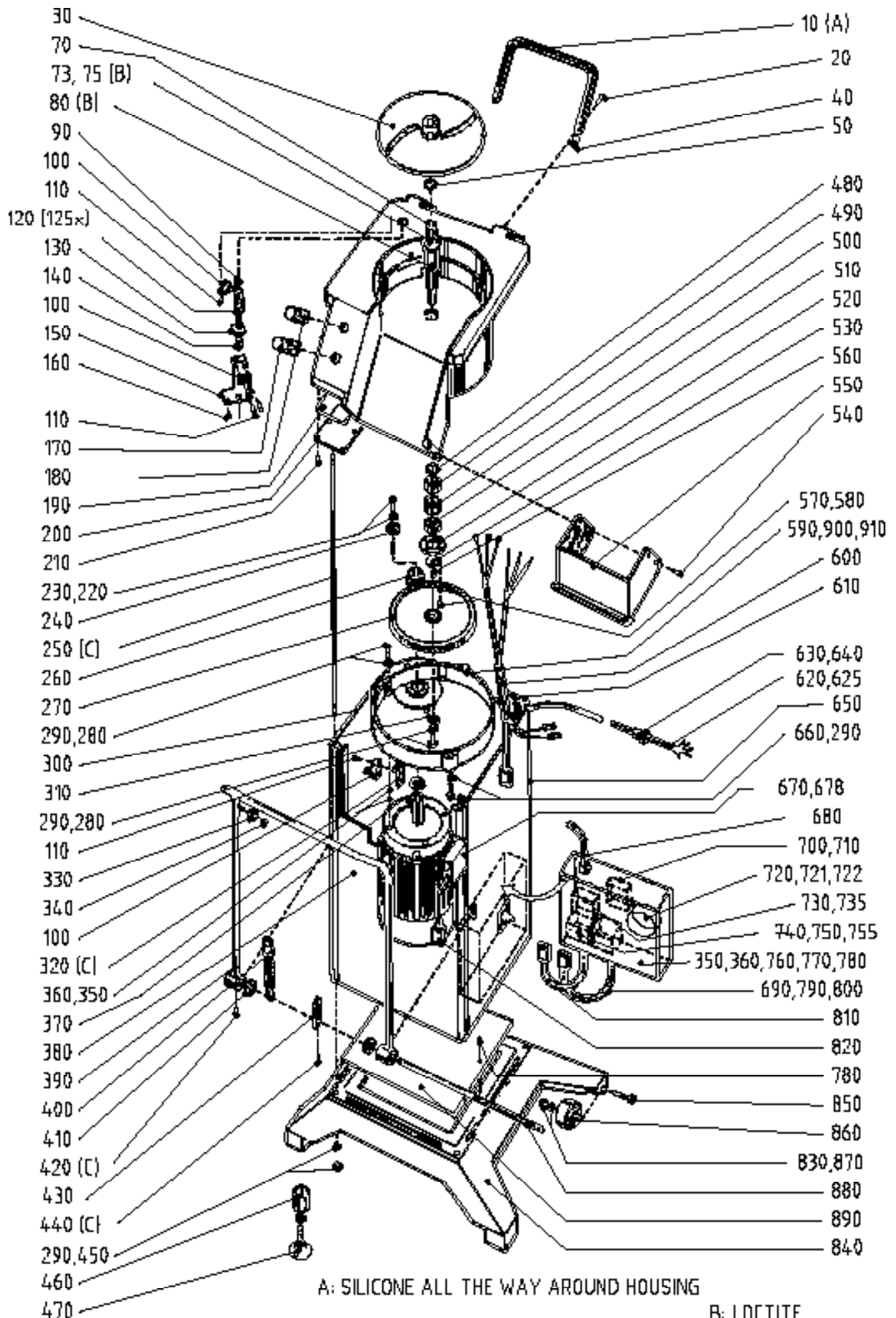

VEGETABLE PREPARATION MACHINE RG-400

No. on drawing	Item No.	Description	Pcs
10	3110	Handle knifechamber	1
20	14376	Screw MCS M8X30 A270	2
30	3086	Ejector plate	1
40	10344	Plug GL 320 black	2
50	10311	Seal ring V-35S	1
70	3180	Knife shaft compl.	1
73	40548	Carrier pin	1
75	14844	Locking screw PSS M8X 12 A2 70	1
80	3152	Carrier pin for ejector plate	2
90	10325	Seal ring 17.1X1.6	1
100	15586	Safety switch KB5FKR-U	3
110	14308	Screw MCS M3X20 A270	6
120	33317	Shaft safety switch M99	1
125	3125	Shaft f. safety switch	1
130	3126	Thrust plate	1
140	10324	Spring, safety switch 22510	1
150	3124	Bracket f. safety switch	1
160	14512	Screw M6SH M5X10 A2 70	3
170	15439	Push button o complete	1
180	15440	Push button 1 complete	1
190	10323	Seal ring dia. 2.4 L=325	1
200	3096	Cover plate	1
210	14662	Screw KFSS ST3.5X13 A2 70	6
220	14564	Screw M6SH M10X30 A2 70	1
230	14090	Washer FBB 10.2 A2	1
240	3159	Washer for geel wheel, motor	1
250	3061	Pull rod M 8	4
260	3083	Gear wheel 52.6	1
270	3057	Gear wheel 173.2	1
280	14544	Screw M6SH M8X22 A2 70	5
290	14088	Lock washer FBB 8.2 A2	7
300	3060 4	Machine housing left part	1
310	3158	Washer gear wheel, knife shaft	1
320	3130	Bracket f handle locking	1
330	37217	Roller locking handle	2
340	10326	Lock ring SGA 8 SS	2
350	14084	Lock washer FBB 4.1 A2	1
360	14629	Screw RTK ST3,5X9,5	2
370	10342	Seal ring basl 42X55X7	1
380	3060 1	Machine housing front part	1
390	3078	Lock handle	1
400	3111	Tension spring	2
410	3089	Bushing for lock handle	2
420	14849	Screw TSS 8X25 A2 70	2
430	3108	Stopper for lock handle	1
440	14845	Screw TSS 8X15 A2 70	1
450	14048	Nut M8	4
460	3154	Protection tube	2
470	10328	Foot Rubber	2
480	10318	Seal ring 25X40X7	1
490	10320	Ball bearing 6205-2RS	1
500	3055	Spacer ring 20/28	1
510	10319	Ball bearing 6304 2RS	1
520	3054	Ball bearing cover	1
530	3056	Spacer ring 20/28	1
540	14443	Screw LKCSF M5X12 A2 70	4
550	3112	Safety guard	1

VEGETABLE PREPARATION MACHINE RG-400

No. on drawing	Item No.	Description	Pcs
560	10321	Key PKR 6X6X16	1
570	14085	Lock washer FBB 5,1 A2	4
580	14343	Screw MCS M5X12 70	4
590	3120	Motor bearer	1
600	3191	Wiring loom, machine	1
610	3060 3	Machine housing back part	1
620	15144	Supply cord CB 3 phse	1
625	3193	Supply cord US	1
630	15381	Cable ret PR 22.5 dia 15	1
640	15443	Nut PR 22.5/PG16 metal	3
650	3060 2	Machine housing right part	1
660	14551	Screw M6S M8X60 A2 70	3
670	15432	Motor 208-220 3 60 UL	1
678	15435	Motor 400-415 3 50	1
680	15229	Cable retainer PR22,5	1
700	15442	Pole changing switch incl knob	1
710	14602	Screw FSS ST2,9X13 A2 70	2
720	15589	Transformer 208-240v 22-26v UL	1
721	15611	Transformer 400/380V-24 50VA	1
722	15689	Transf. 440-415V 24 100VA 80C	1
730	15814	Overl. rel. RF12400	1
735	15816	Overload RF120630	1
740	15825	Contactactor 11BG0910A024	2
750	14630	Screw RTS ST3,5X13 FZB	8
755	15718	Varistor S20K510	1
760	15587	Box CT-841	1
770	15193	Ground plate M4	1
780	14731	Screw RXK ST4,8X9,5	6
790	3195	Wiring loom pole changening	1
800	15226	Cable seal 20,4	2
810	3192	Wiring loom electrical box	1
820	3194	Wiring loom motor	1
830	14028	Nut MHM M8	2
840	3117	Base	1
850	14553	Screw M6S M8X70 A2 70	2
860	10327	Wheel 85 RNP	2
870	10374	Washer 3MM nylon	4
880	3109	Shaft lock handle	1
890	3143	Fan plate	1
900	10322	O-ring 236,5X2,4	1
910	10350	Grease for gear box, GB0, 1kg	1

**VEGETABLE PREPARATION MACHINE RG-400i/ RG-400:
MANUAL PUSH FEEDER, ERGO-LOOP**

No. on drawing	Item No.	Description	Pcs
10	10335	Lock ring SGA 10	6
20	3298	Pivot L=38	1
30	33431	Push handle Ergo	1
40	3066	Link	1
50	3297	Pivot L=51	1
60	37148	Stand complete	1
70	14149	Screw MFS M5X16	1
80	37244	Bushing	1
90	37160	Shaft stand	1
100	3212	Pin for stand L=28	1
110	10452	Plug SFL 14	1
120	3074	Bushing for stand	2
130	37061	Feeder plate including shaft	1
140	3299	Pivot L=34	1
150	3129	Decorating device 3ph	1
160	3162	Wrench	1
170	3257	Guide knob	3

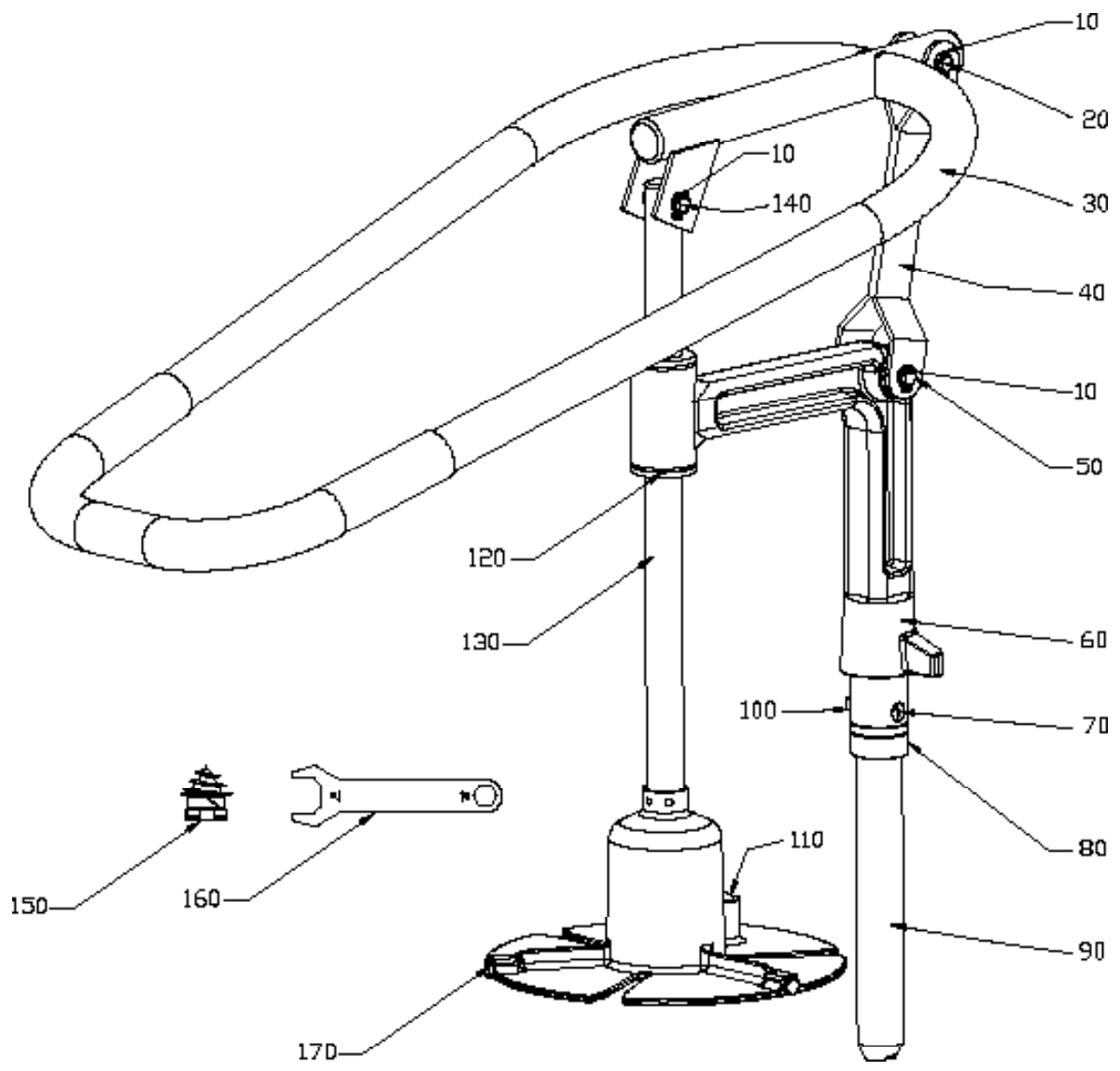

VEGETABLE PREPARATION MACHINE RG-400: FEED CYLINDER

No. on drawing	Item No.	Description	Pcs
10	33305	Slide knob dia. 10X4	1
20	40839	Slide knob	2
30	14714	Screw CSS ST3,5X9,5	1
40	3085	Stopper, 4-tube/push feed att	1
50	3253	Bayonet sleeve	1
60	10334	Spring ST-TFR 0,5X4X35	2
70	14243	Screw MKFS M5X10	1
90	3234	Locking clutch f feed cylinder	1
100	3281	Plastic washer 18-6-2	1
110	10436	Plastic washer 05-6-15-3	1
120	14464	Screw LKCSF M6X16	1
130	3076	Bushing 25/34	1
140	3068	Bushing cover	3
150	14682	Screw KFSS ST4,8X13	3
160	3134	Knife	3
170	3233	Nut M5	9
180	14326	Screw MCS M4X16	1
190	14004	Nut M6M M4 A2 70	1

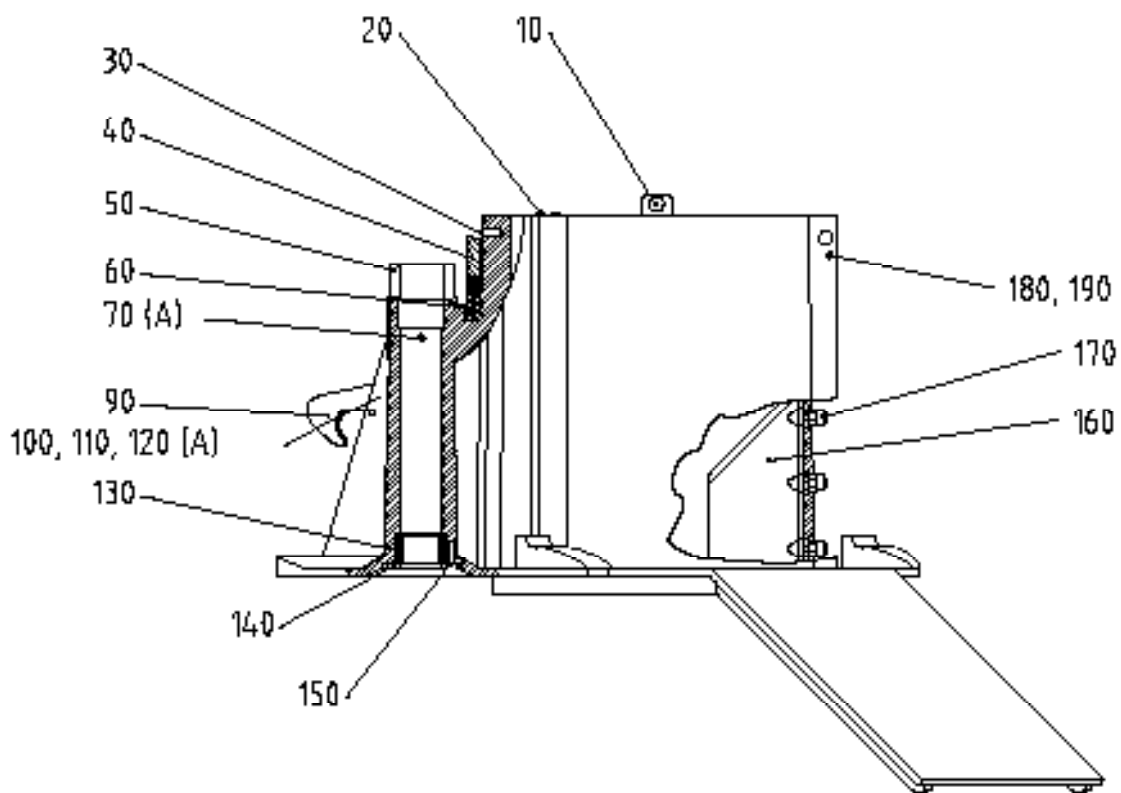

A: LOCTITE

VEGETABLE PREPARATION MACHINE RG-400: FEED HOPPER

No. on drawing	Item No.	Description	Pcs
10	3311	Agitator arm	1
20	14464	Screw LKCSF M6X16	1
50	10345	Plug GL 28 black	1
60	3149	Stud screw	1
70	10454	Ball RB-6.35	1
80	10453	Spring 1X5X17	1
90	10343	Handle I280/65-M8	1
100	3131	Bayonet pin	1
110	3253	Bayonet sleeve	1
120	14243	Screw MKFS M5X10	2
130	3266	Bushing	1
140	3094	Shaft	1
145	37226	Shaft w. bushing	1
150	3234	Locking clutch f feed cylinder	1
160	3281	Plastic washer 18-6-2	1
170	10436	Plastic washer 05-6-15-3	1
180	3039	Feed cylinder for feed hopper	1
190	3076	Bushing 25/34	1
200	3068	Bushing cover	1
210	14682	Screw KFSS ST4,8X13	3
220	14026	Domed head nut MHM M6	5
250	3246	Stirrer for hopper	1
260	3232	Guide	2
270	14865	Stud screw SK6SS A4	4
280	3249	Agitator device complete	1
290	3162	Wrench	1
300	10521	Socket wrench NV10	1
310	33328	Hopper insert complete	1

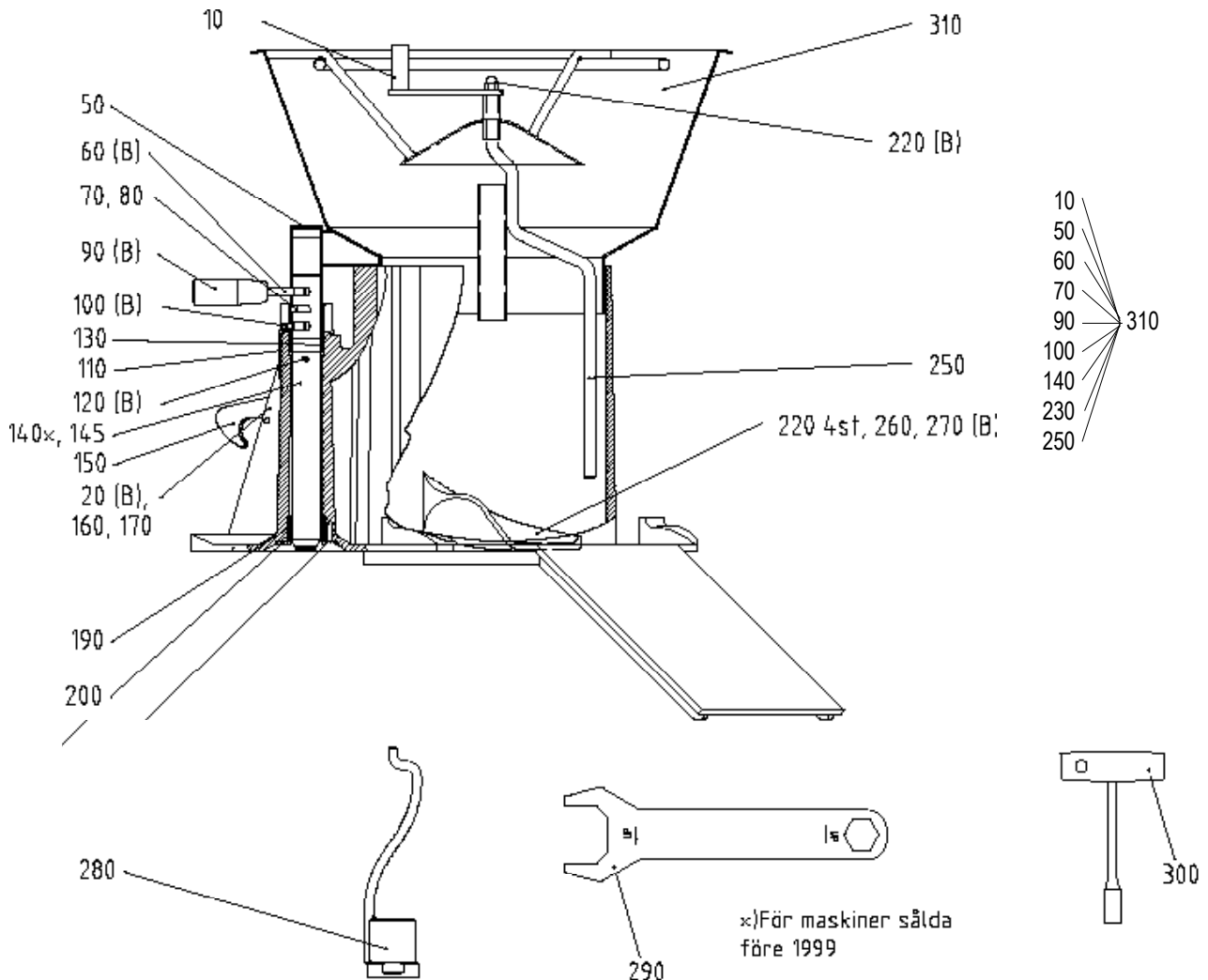

VEGETABLE PREPARATION MACHINE RG-400: 4-TUBE INSERT

No. on drawing	Item No.	Description	Pcs
10	3254	Stand	1
20	3149	Stud screw	1
30	10343	Handle I280/65-M8	1
40	10454	Ball RB-6.35	1
50	10453	Spring 1X5X17	1
60	3131	Bayonet pin	1
70	3266	Bushing	1
80	3094	Shaft	1
85	37163	Shaft	1
100	3251	Washer	2
110	14484	Screw LKCSF M8X16	2
120	10329	Plug IR20/40/1,5 S	1
130	10455	Plug IKPT 1715S	2
140	3256	Spacer 25	1
150	3255	Spacer 16	1
160	14395	Screw MC6S M8X40	2
170	3279	Sign warning	1
190	10345	Plug GL 28 black	1
200	3139	Pestle dia. 55	1
210	3138	Pestle dia. 31	1
220	3204	Locking bolt TR12V	1
230	33354	Shaft w. bushing M99	1

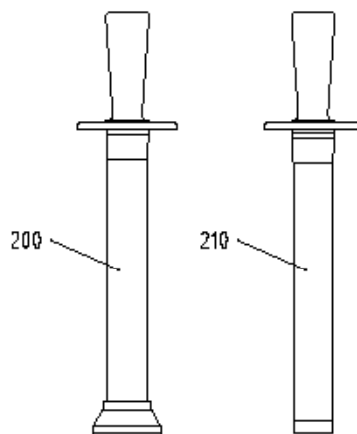
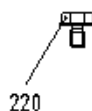
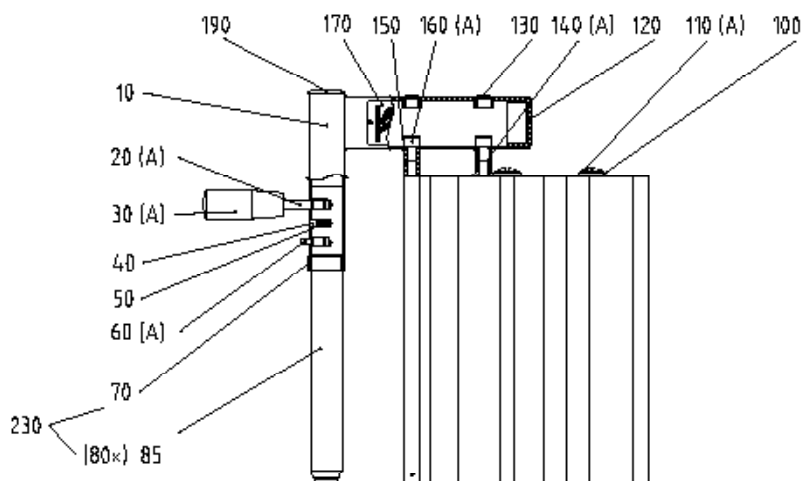

(x) FÖR MASKINER
SÅLDA FÖRE 99

A: LOCTITE

**VEGETABLE PREPARATION MACHINE RG-400i/ RG-400:
PNEUMATIC PUSH FEEDER**

No. on drawing	Item No.	Description	Pcs
10	3098	Stand	1
20	3212	Pin for stand L=28	1
30	14149	Screw MFS M5X16	1
40	37244	Bushing	1

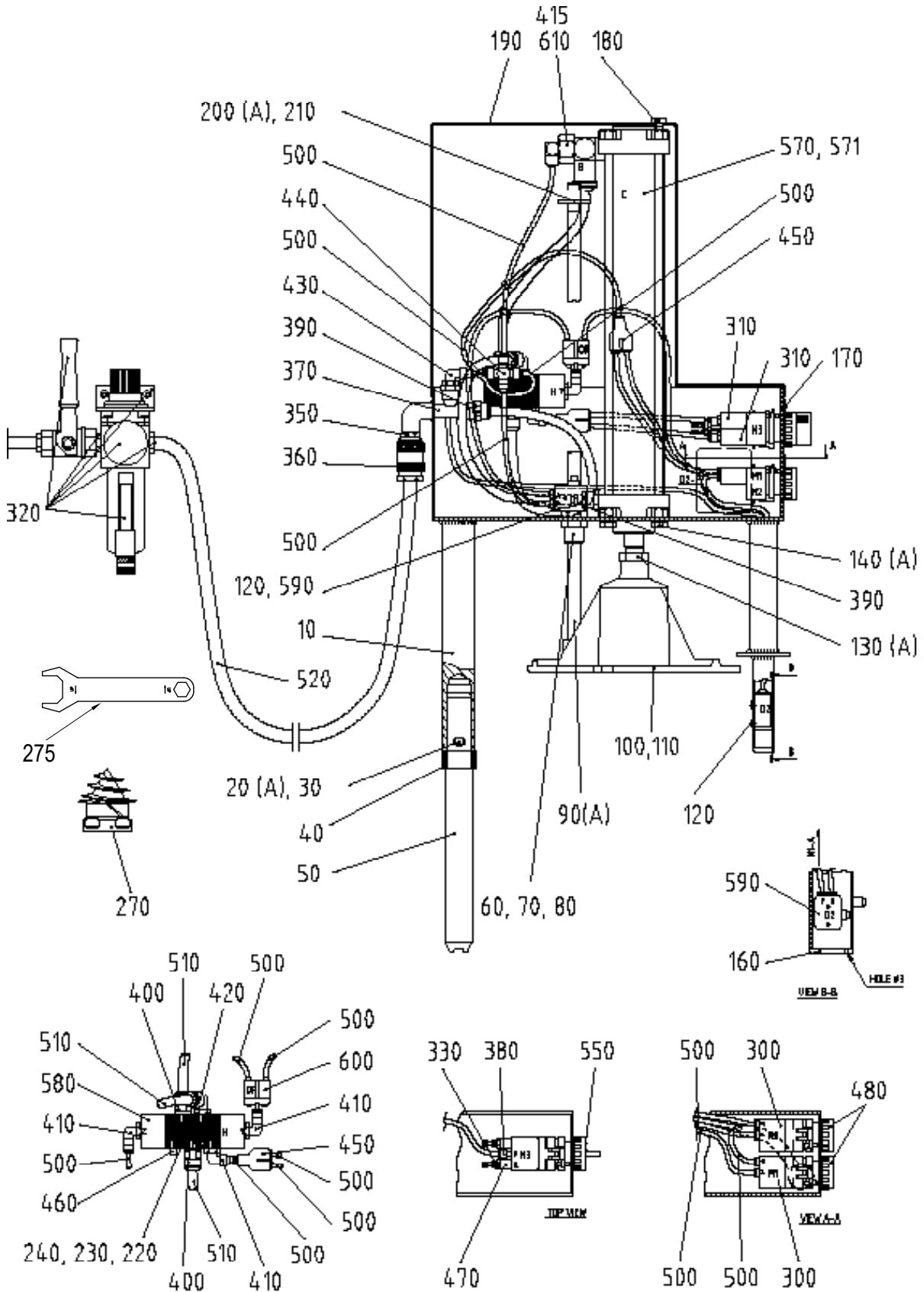

THREAD LOCKING COMPOUND: LOCTITE

A: LOCTITE

VEGETABLE PREPARATION MACHINE RG-400i/ RG-400: PNEUMATIC PUSH FEEDER

No. on drawing	Item No.	Description	Pcs
50	37160	Shaft stand	1
60	3106	Bearing holder	1
70	10348	Bushing PM12/14X15DX	2
80	3101	Nut M18	1
90	3080	Operation rod	1
100	37040	Piston	1
110	3257	Guide knob	3
120	14224	Screw MKFS M4X12	4
130	3295	Nut M16X1,5 low	1
140	14542	Screw M6SH M8X16 A2 70	4
160	10329	Plug IR20/40/1,5 S	1
170	10367	Sign 1-3-2	1
180	14374	Screw MCS M8X20 A2 70	1
190	3099	Cap	1
200	14012	Nut M6M M12	1
210	3105	Thrust washer	1
220	14230	Screw MKFS M4X30	2
230	14004	Nut M6M M4 A2 70	3
240	14084	Lock washer FBB 4.1 A2	2
270	3129	Decorating device 3ph	1
275	3162	Wrench	1
300	10109	Valve 234-000	2
310	10354	Valve 245 000	2
320	10392	Regulator Compl.	1
330	10356	Valve reducer MCO-702-M5	2
350	10112	Adaptor 5180 1/4	1
360	10357	Quick connector 5084-10/8	1
370	10120	Tee niple 1/4	1
380	10358	Coupling 6512-4-M5	2
390	10095	Coupling 6510-8-1/4	2
400	10359	Coupling 6510-8-1/8	2
410	10117	Elbow coupling 6520-4-1/8	3
415	10097	Elbow coupling 6520-4-1/8	1
420	10360	Elbow coupling 6520-8-1/8	1
430	10361	Elbow coupling 6520-4-1/4	1
440	10119	Cross coupling 6600-4	1
450	10362	Coupling Y 6560-4	2
460	10363	Silencer 2991-1/8	1
470	10364	Silencer 2905-M5	2
480	10492	Push button 200-895 start/stop	2
500	10234	Hose PA12 4-2.7	1
510	10235	Hose PUR-8/5.7	1
520	10368	Hose PV10/8	1
550	10493	Twist knob speed control	1
570	10490	Cylinder complete	1
571	33311	Gasket kit for cylinder	1
580	10352	Valve 358-033-1/8	1
590	10108	Valve 234-945	2
600	10353	Valve or 81540 001	1
610	10240	Valve 7880-08-13	1
620	10546	T-coupling	1
630	10547	Reduce	1
640	10548	Gauge	1